

COMMERCIAL

**CONCEALED
FASTENERS**

COVERAGES
MI 200: 18"
MI 210: 17 5/8"

MINIMUM SLOPE
1/4 : 12

**OPEN FRAMING/
SOLID SUBSTRATE**

PANEL DESCRIPTION

- Applications: Commercial and Industrial
- MI 210, 17 5/8" coverage, enhances wind load rating
- Conditions may require side lap butyl sealant
- Limited 40-year warranty paint
- Finishes on MI 200 & MI 210: 10 standard PVDF colors – 24 gauge
- Corrosion Protection on Substrate:
 - AZ-50 (ASTM A792) for painted Galvalume®
 - G-60 (ASTM A653) for painted Galvanized
 - G-90 (ASTM A653) for PVDF painted 24 gauge
- Sheet lengths: One inch increments to any length
- Optional: 22 gauge steel, custom colors, and pre-painted aluminum
- For color availability, cool roof specs, and other panel info, please see our website: www.metallionindustries.com

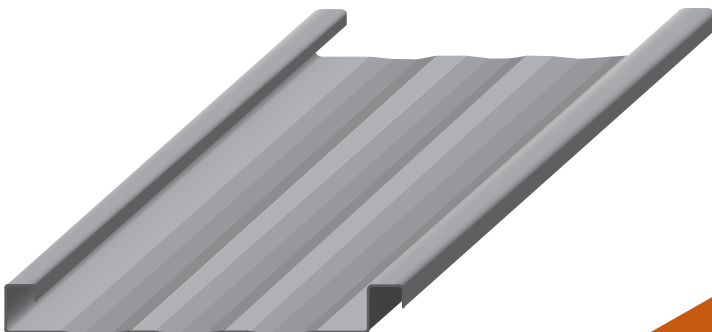

TESTING DATA



- UL 2218 Impact Resistance
- UL 790, 263 Fire Resistance
- UL 580 Uplift Resistance

PANEL FASTENING

CLIP & FASTENER INFORMATION

Fasten Clip to Wood using:
#10-9 Low Profile Wood Screw

Fasten Clip to Steel using:
#12-14 Low Profile Drill-Tip Screw

Types of clips vary according to installation and application needs. Floating clips accommodate thermal expansion and contraction.

Screw thread should protrude no less than 1/4" through the substrate.

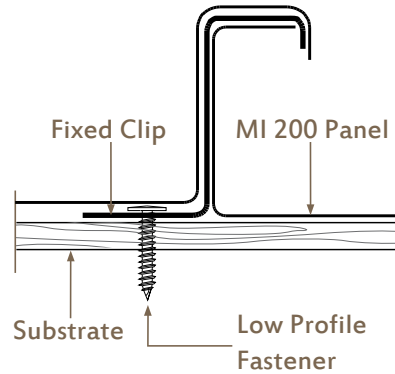

UL PANEL CLIP

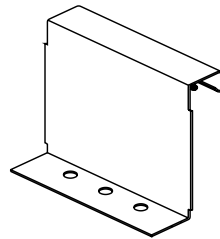

Fixed Clip

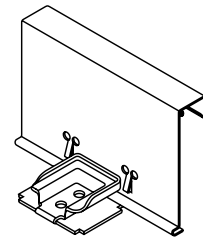

Floating Clip

MI200 & MI210 Allowable Loads (lbs/ft ²) per span			Wind Load Factor = 1.0 (not increased 33%)										
Ga	Span Type	Load Type	2'	2.5'	3'	3.5'	4'	4.5'	5'	5.5'	6'	6.5'	7'
24	Single	L/180	178	142	115	84	64	50	41	33	28	24	20
		L/240	178	142	115	84	64	50	41	33	28	24	20
		L/360	178	142	115	84	64	50	41	33	28	24	19
	Double	L/180	223	156	115	84	64	50	41	33	28	24	20
		L/240	223	156	115	84	64	50	41	33	28	24	20
		L/360	223	156	115	84	64	50	41	33	28	24	20
	Triple	L/180	223	178	127	94	73	58	47	38	32	27	23
		L/240	223	178	127	94	73	58	47	38	32	27	23
		L/360	223	178	127	94	73	58	47	38	32	27	23

24 gauge has .0236" min Substrate Thickness, 50 KSI Tensile (UL)

Panel Width: 18", ASTM A653
Loads are averages from similar products with design loads meeting AISI specifications

Oil Canning: Flat metal surfaces can display waviness, commonly referred to as "oil canning", which is an inherent characteristic of steel. "Oil canning" is not a defect and therefore not an acceptable reason for rejection.